

PRODUCT CUT SHEET

2" HORIZONTAL FAUXWOOD - CORDLESS

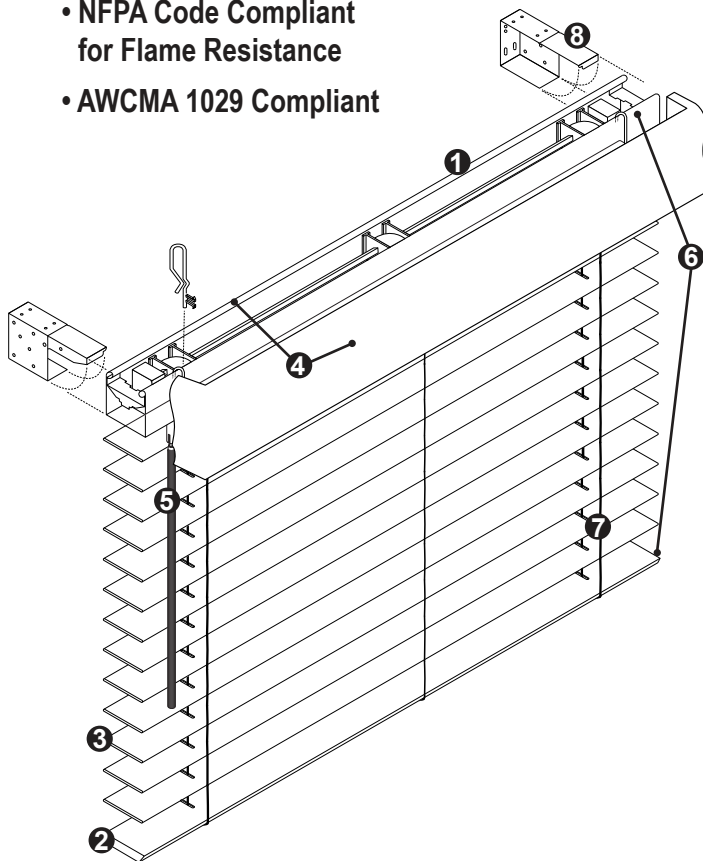

- Cordless operation
- 21" drop wand tilt
- Smooth or embossed slat finish
- Snow White color
- 3" crown valance with returns
- Optional cloth tapes
- Optional motorization
- 2-on-1 or 3-on-1 available for larger blinds
- NFPA Code Compliant for Flame Resistance
- AWCMA 1029 Compliant



SPECIFICATIONS:

1. **Headrail** 1.5" High x 2" Wide low profile PVC
2. **Bottomrail** Rectangular, hollow PVC bottomrail with end caps
3. **Slats** 2" Wide Faux Wood PVC
4. **Valance** 3" curved profile crown valance with 3/4" returns on all inside mount, full return on all outside mount
5. **Wand Tilter** The tilt wand is electro zinc coated solid steel measuring 1/4 inch at its widest points. The tilter wheel is made of acetal thermoplastic and the gear and housing are made of steel to provide smooth, quiet operation.
6. **Cordless** Cordless design with a simple raise and lower by grasping the bottomrail. Incorporates a "crash proof" safety feature that locks blind automatically upon release of bottomrail.
7. **Cord Ladder** Polyester braided cord ladders provide maximum strength and flexibility with minimum stretch ensuring the slats overlap correctly when in the closed position. Standard ladder spacing between slats is 44mm/~1.73in.
8. **Installation Brackets** Brackets are made of steel and color matched to the headrail. The front is hinged to lock the headrail in place. For blinds over 60" wide a center bracket will be provided. Extension and hold down brackets are available at no charge when requested.